

- An easy to follow step by step guide.
- Complete materials check list.
- List of all tools required.

In this brochure we have suggested measurements but you can easily change them to suit your particular needs.

Before you commence your timber fence project we recommend you read this step by step guide fully so that you have a good understanding about how you can best tackle your project.

Easy to use
step by
step guide

List of all
tools
required

Complete
material
checklist

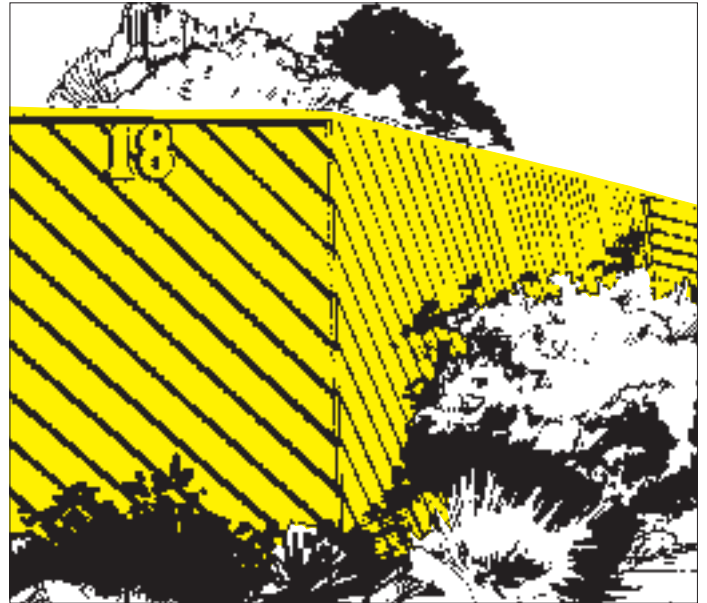

PREPARATION

RE-SEAL ALL CUT
ENDS OF TIMBER

USE GALVANISED FIXINGS ON
ALL OUTDOOR PROJECTS

Choosing a design

The most important things to consider when choosing a fence design are:

(a) BLENDING with the environment. Choose a style that complements the character of your home and garden.

(b) PRACTICAL aspects such as privacy, outlook and wind protection.

If wind is a problem on your site do not try to 'block out' with a solid structure as this may produce turbulence more damaging than the wind it aims to prevent. You need a more open fence design to filter the wind and cut down its speed.

(c) COSTS. Timber is still one of the most economical and attractive fencing materials. It is easy to work with and requires little maintenance.

Tools Required

- Handsaw
- Circular saw
- Power drill and bits
- Wood chisel
- Tape measure
- Carpenters Pencil
- Nail punch
- Shovel
- Crow bar
- Hammer
- Spanner
- String line
- Spirit Level
- Combination square
- Sandpaper
- Paintbrush

Materials Check List

- POSTS 125 x 75mm Cypress Pine
- RAILS TOP & BOTTOM 75 x 50mm Unseasoned Hardwood or 70 x 45mm Seasoned Treated Pine
- CENTRE 75 x 38mm Unseasoned Hardwood or 70 X 30mm Seasoned Treated Pine
- PLINTHS 150 x 25mm Unseasoned Hardwood or Treated Pine
- PALINGS 100 x 12mm Treated Pine
150 x 12mm Treated Pine
- POST CAPITALS Turned Treated Pine
- PICKETS 70 x 19mm Treated Pine or Cypress Pine
- SOLE PLATES 300mm x 150 x 38mm Cypress Pine
- BRACING TIMBERS 50 x 25mm Unseasoned Hardwood
- NAILS 100mm x 4.25 Galvanised Bullet Head
75mm x 3.75 Galvanised Bullet Head
40mm x 2.0 Galvanised Flat Head
50mm x 2.8 Galvanised Flat Head
- PREMIXED CONCRETE OR CEMENT
- RESEAL SPRAY

Sizes quoted to be used as a guide only

For safety use goggles, gloves and dust mask

Styles

When selecting the actual style of your fence you will also need to determine the timber type or species that best suit your type and style or fence. For your convenience we have illustrated a number of styles on this page.



RANCH STYLE
Pleasing light and shade effects can be created with this rustic ranch style fence. It is an ideal wind filter and is great for growing creepers.

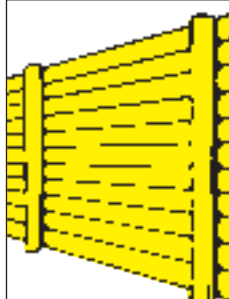

LOG FENCE
A rustic appearance can be added with a treated pine log fence or retaining wall.



PALINGS
The humble paling fence is still the most popular style on common boundaries.

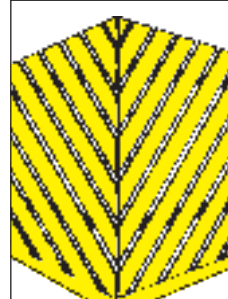

HERRINGBONE
A striking variation on the open board fence which offers maximum privacy while still letting through air and light.

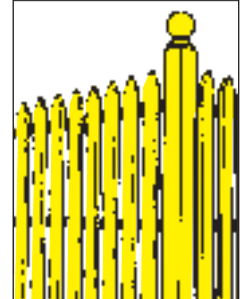

PICKETS
Add that distinctive touch of charm to your home with your own picket fence.

Boundaries and council requirements

If there are no survey pegs on your site you should have a survey made by a registered surveyor.

Local councils may also permit only certain types of fencing in your area.

Before you start

Always check with your council authority as to local regulations, permits etc.

You should also talk to your neighbours about sharing the cost for boundary fences.

1. The standard paling fence

The following step by step guide has been set out for a paling fence, still the preferred and most common boundary fence.

2. Setting the posts

Solid timber posts for the paling fence are usually 125mm x 75mm (5" x 3") and should be set 600mm deep for a fence up to 1.8m high. Depending on the size and construction of a fence they are usually placed 2 to 2.7m apart.

Mark out the position of the posts holes with a stake. Ensure that all holes are aligned by stretching a string line between the corner post positions and

locate post holes 2700mm (centre to centre). All post holes should be located so that posts are flush to stringline when level upright (Fig. 2).

When digging the holes it is not necessary to make the holes very wide as you will only have more to fill once the posts are in position. Make sure bottom of hole is "rammed" solid and place a sole plate 225 x 150 x 38mm in the bottom of the hole. Set posts on top of the sole plate, make sure they are plum (level upright) using your level (Fig. 1). Follow the diagram for setting posts in concrete. Attach temporary braces to the posts so that it stays upright and straight. Timber battens (50 x 25mm) make ideal braces (Fig. 2).

Concrete mixture should be a 4.2.1

mix – 4 parts aggregate or blue metal, 2 parts sand, 1 part cement. Alternatively you can use 6 parts fine crushed rock (up to 20mm) to 1 part cement. BOWENS stores can supply readymix concrete mix.

Finish top of mixture with dome shape to allow for water run-off.

Allow concrete to set 3 - 4 days and remove temporary braces.

3. Check out posts

Check out all posts for flush fixing of timber rails with saw and chisel (Fig. 3).

Top rail to be fixed 75mm from top of post or if capping is required, check out flush with top of posts (Fig. 8). Bottom rail to be fixed 300mm from ground level

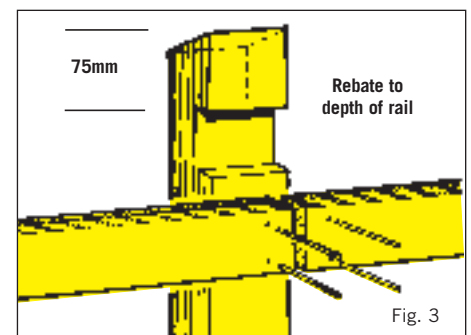
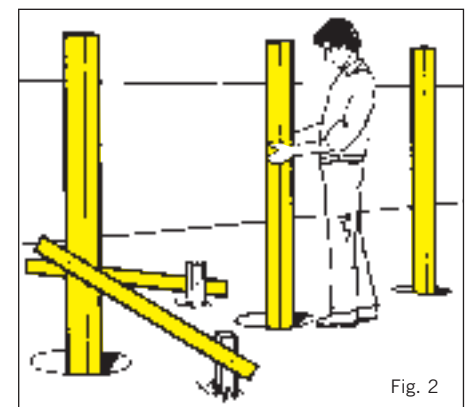
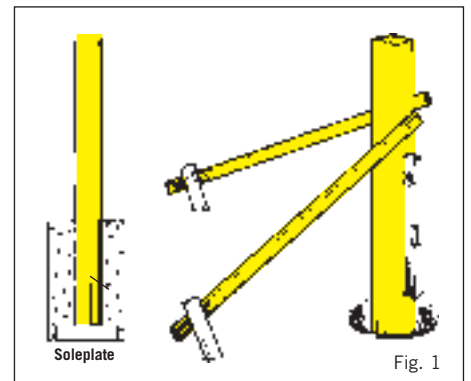

Timber Fence

(Fig. 4).

Centre rail to be fixed in centre of both rails.

Angle cut the top of posts for water run-off.

4. Fixing rails to posts

Top and bottom rails are usually 75 x 50mm OB Hardwood or 70 x 35mm Seasoned Treated Pine with centre rails 75 x 38mm or 70 x 35mm Seasoned Treated Pine.

Fix top rail 75mm from top of post (Fig. 3) and bottom rail 300mm from ground.

Where rails butt together, join at posts (Fig. 4) using galvanised nails to avoid discolouring the timber. Predrill ends to avoid splitting.

These methods for fixing rails to posts may vary depending on the design of the fence, however, those shown are a useful guide.

5. Fix plinths

Nail plinths to bottom of posts. Join at posts where plinths butt together (Fig. 5).

Use galvanised flat head nails to avoid discolouring timber. Top of plinth should be a

maximum of 175mm below bottom rail (Fig. 5).

6. Fix palings

You can butt palings together and nail along the line of the rails. Alternatively, a stronger, more attractive fence can be made by overlapping the palings. First attach the 150mm underpalings 50mm apart making sure they are level (Fig. 6). A 50mm board as a spacing template

can be helpful. Next, nail on the 100mm overpalings by driving through overpaling so that they do not go through underpalings allowing them to shrink without splitting (Fig. 7). Use 40 x 2.0mm galvanised flathead nails for underpalings and 50 x 2.8mm flathead galvanised nails for overpalings.

For more information on this or other timber projects, contact your nearest BOWENS store.

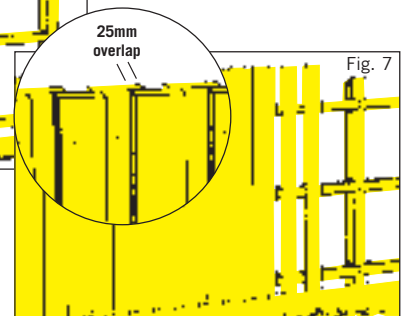
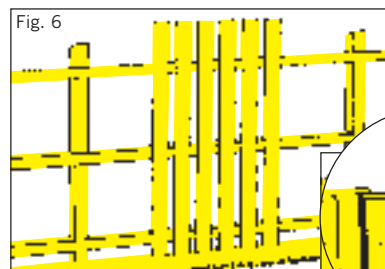
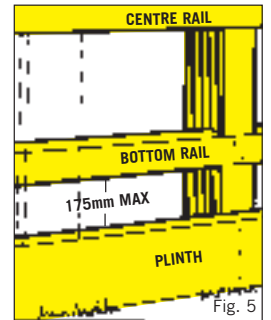
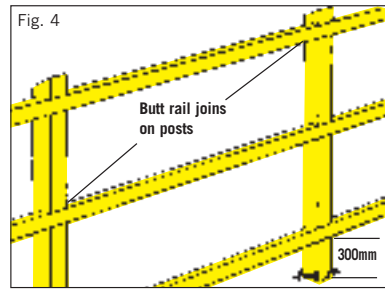

Cappings

Cappings

Capping (Fig. 8) will improve the life and enhance the appearance of your fence. Top rails must be fixed flush with posts which must be trimmed horizontally and palings cut flush with top rail. Profile of capping must be shaped for water run-off and fully cover nails and palings. Joins should be mitred. Galvanised nails should penetrate top rail at least 35mm.

Picket Fences

Add distinction, charm and value to your home with a picket fence. BOWENS stock long life treated pine and cypress pickets in the popular Windsor Profile (Fig. 9). Other profiles are available to order.

Post Caps

Turned oregon or treated pine post capitals are available in round, acorn or windsor pattern. Caps glue into drilled hole in post top. First determine the configuration you

plan to use (i.e. rise and fall, concave etc.). This will help you order correct length pickets. Refer to illustrations (Fig. 10 and 11) for method of constructing picket fence.

Posts (100 x 100mm) and rails (75 x 50mm) to be set and fixed as per paling fence posts. Rebate rails into rear of posts. Join rails at posts (Fig. 10).

For best effect, pickets should be spaced 20 to 25mm apart. Allow 10 or 11 pickets per metre when calculating materials.

Rails, posts and plinths should be "dressed all round". Fix plinths so that front of plinth is flush with front of pickets (Fig. 11).

Fence stains and finishes

A quality fence stain will add years to the life of your fence. Use quality acrylic paint to protect and enhance your picket fence. BOWENS stock a great range of fence finishes.

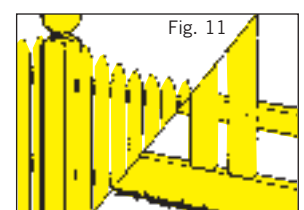
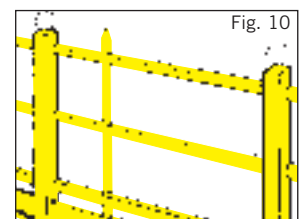
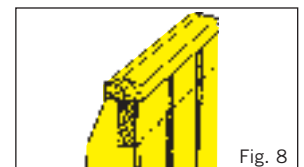

Number 03

Call Toll Free

1800 333 162

or return this coupon to:

Bowens The Builders Choice
P.O. Box 1377,
Vesper Drive,
Narre Warren 3805

Please send me the information I have marked here;

Name: _____

Address: _____

Postcode: _____

Phone: _____

 Yes I would like information on other 'How to Build' projects

- | | |
|---|--|
| <input type="checkbox"/> How to Build a Pergola | <input type="checkbox"/> How to Build Timber Gates |
| <input type="checkbox"/> How to Build a Carport | <input type="checkbox"/> How to Build a Timber Fence |
| <input type="checkbox"/> How to Build Workbench | <input type="checkbox"/> How to Build a Gazebo |
| <input type="checkbox"/> How to Build Timber Steps | <input type="checkbox"/> How to Build a Feature Wall |
| <input type="checkbox"/> How to Build Timber Shelving | <input type="checkbox"/> How to Build a Timber Deck |

IMPORTANT: This project sheet has been produced to give basic information and our helpful staff are available to answer any questions you may have. However, the use of this information is on the understanding that Bowens (including it's author, servants and owners) disclaim all and any liability for any damages or other amounts found to be recoverable in relation to such information, even when given negligently or attributable directly or consequently upon any act or omission by or on behalf of Bowens. The user is advised to contract a qualified tradesman, when expert information or services are required.

WARNING: Always check with your council authority regarding by-laws or regulations which may be applicable to this project.

Many Great Locations

- **Croydon**
352 Dorset Road
T. 9723 0394
- **Hallam**
48-52 Hallam South Road
T. 9796 3088
- **Hastings**
2 Graydens Rd
T. 5979 1267
- **Laverton North**
163 Cherry Lane
T. 9353 7700
- **Mount Evelyn**
26 York Road
T. 9736 2588
- **North Melbourne**
135-173 Macaulay Road
T. 9328 1041
- **Oakleigh South**
717 Warrigal Road
T. 9579 1188
- **Rowville**
963 Stud Rd, Cnr. Kelletts Road
T. 9763 7522
- **Taylors Lakes**
45 Melton Highway
T. 9390 8899

Bowens

THE BUILDERS CHOICE