

# HOW TO BUILD YOUR OWN TIMBER STEPS

**STEP  
BY STEP  
GUIDE**  
No. **9**

## MATERIALS CHECK LIST

■ STRINGERS	290 x 45 mm F7 Seasoned Treated Pine
■ TREADS	290 x 45 mm F7 Seasoned Treated Pine
■ LEDGER	90 x 45 mm F7 Seasoned Treated Pine
■ CLEATS	70 x 35 mm Treated Pine
■ POSTS (to hand rails)	90 x 90 mm Cyprus Gold or H4 Treated Pine
■ HANDRAILS	90 x 35 mm Dressed F7 Seasoned Treated Pine
■ BALUSTERS	42 x 35 mm Seasoned Treated Pine
■ CAPPING RAIL	140 x 35 mm F7 Seasoned Treated Pine
■ POST SUPPORT	(to concrete) Teco Galvanised Post Saddle
■ MASONRY ANCHOR	Countersunk to suit bracket
■ MASONRY ANCHOR	To suit post support
■ GALV. COACH BOLTS	100 x 10 mm (Ledger to Fascia)
■ GALV. COACH BOLTS	125 x 10 mm (to Post Support)
■ BRACKETS	(Stringer Floor Support) Heavy Duty Galvanised Steel with countersunk holes
■ NAILS	70 x 3.75 mm Galvanised Bullet Head
■ RESEAL	To seal cut timber ends

SIZES  
QUOTED  
TO BE USED  
AS A GUIDE  
ONLY

## TOOLS REQUIRED

- Handsaw
- Circular saw
- Power drill
- Tape measure
- Carpenters Pencil
- Wood Chisel
- Nail punch
- Hammer
- Spanner
- Carpenters Square
- Paintbrush
- Sandpaper
- Level

**FOR SAFETY USE GOGGLES,  
GLOVES AND DUST MASK.**

# HOW TO BUILD YOUR OWN TIMBER STEPS

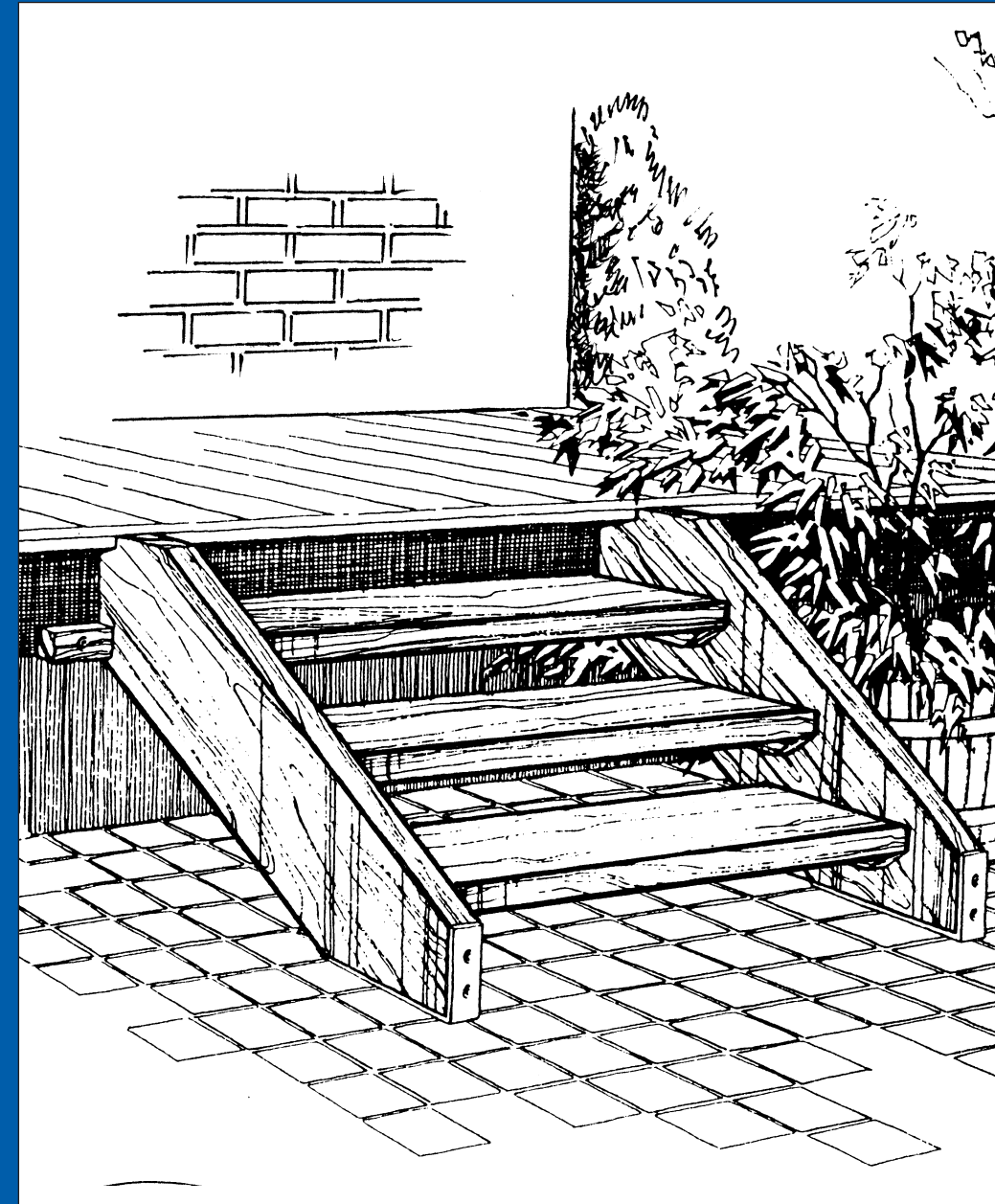

9

**EASY  
TO FOLLOW  
STEP BY STEP  
GUIDE**

**COMPLETE  
MATERIALS  
CHECK LIST**

**LIST  
OF ALL  
TOOLS  
REQUIRED**

**Bowens**  
THE BUILDERS CHOICE

- |  |  |   |   |  |
|--|--|---|---|--|
| <b>Croydon</b><br>352 Dorset Rd<br>Ph 9723 0394      | <b>Hastings</b><br>Graydens Rd<br>Ph 5979 1267     | <b>North Melbourne</b><br>135-173 Macaulay Rd<br>Ph 9328 1041 | <b>Rowville</b><br>963 Stud Rd<br>Ph 9763 7522        | <b>Prefabrication Plants</b>                       |
| <b>Epping</b><br>13 Scanlon Drive<br>Ph 9408 6566    | <b>Laverton</b><br>163 Cherry Lane<br>Ph 9353 7700 | <b>Oakleigh South</b><br>717 Warrigal Rd<br>Ph 9579 1188      | <b>Shepparton</b><br>7 Wheeler St<br>Ph 5822 2364     | <b>Dandenong</b><br>267 Hammond Rd<br>Ph 9792 2888 |
| <b>Hallam</b><br>48-50 Hallam Sth Rd<br>Ph 9796 3088 | <b>Mt Evelyn</b><br>26 York Rd<br>Ph 9736 2588     | <b>Phillip Island</b><br>83-85 Settlement Rd<br>Ph 5952 5633  | <b>Taylors Lakes</b><br>45 Melton Hwy<br>Ph 9390 8899 | <b>Hastings</b><br>Graydens Road<br>Ph 5979 2223   |
|  |  |   |   | <b>Morwell</b><br>8 Jones Road<br>Ph 5135 6781     |

Proprietor: BOWEN & POMEROY Pty Ltd ABN 78 004 174 887 Reg. Office: 48-50 Hallam South Road, HALLAM 3803

[www.bowens.com.au](http://www.bowens.com.au)

[feedback@bowens.com.au](mailto:feedback@bowens.com.au)

CALL TOLL FREE  
**1 800 333 162**  
OR RETURN THIS COUPON TO:  
**BOWENS TIMBER AND  
BUILDING SUPPLIES**  
P.O. BOX 1377, VESPER DRIVE,  
NARRE WARREN 3805

9 NAME: .....  
ADDRESS: .....  
POSTCODE: ..... PHONE:.....

PLEASE SEND ME THE INFORMATION I HAVE MARKED HERE

<input type="checkbox"/> 1 Timber Deck	<input type="checkbox"/> 8 Work Bench
<input type="checkbox"/> 2 Pergola	<input type="checkbox"/> 9 Timber Steps
<input type="checkbox"/> 3 Timber Fence	<input type="checkbox"/> 10 Timber Shelving
<input type="checkbox"/> 4 Feature Wall	<input type="checkbox"/> 11 Timber Gates
<input type="checkbox"/> 5 Carport	<input type="checkbox"/> 12 Handrail
<input type="checkbox"/> 6 Gazebo	<input type="checkbox"/> 13 Privacy Fence
<input type="checkbox"/> 7 Cubby House	<input type="checkbox"/> 14 Retaining Wall

IMPORTANT: This project sheet has been produced to give basic information and our helpful staff are available to answer any questions you may have. However, the use of this information is on the understanding that Bowens (including its author, servants and owners) disclaim all and any liability for any damages or other amounts found to be recoverable in relation to such information, even when given negligently or attributable directly or consequentially upon any act or omission by or on behalf of Bowens. The user is advised to contact a qualified tradesman, when expert information or services are required.  
WARNING: Always check with your council authority regarding by-laws or regulations which may be applicable to this project.



REFER TO COUPON  
ON BACK PAGE FOR  
MORE INFORMATION  
REGARDING THIS  
AND OTHER  
BOWENS PROJECTS

**HELPING YOU BUILD IT BETTER!**

**HELPING YOU BUILD IT BETTER!**

**Bowens**  
THE BUILDERS CHOICE

# STEP BY STEP GUIDE TO BUILDING YOUR OWN TIMBER STEPS

There is often a need for steps as an access to a deck or landing or for use between decks with different levels.

Building your own timber steps is not as difficult as you may first think. If you follow this step by step guide and use the right tools you will find that you can build your own timber steps and save!

Before commencing any further we recommend that you fully read this brochure.

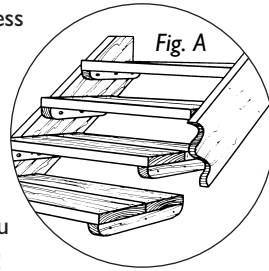

## BASIC COMPONENTS

Steps have several important parts:

- STRINGERS** The side rails of the steps.
- TREADS** The actual walking platforms (minimum clear width 245 mm).
- CLEATS** Bolted to the stringers and to which you fix the treads.
- RISER** Vertical distance or height between the upper surfaces of the treads.
- GOING** The clear tread width.
- PITCH** The steepness or angle of the steps.

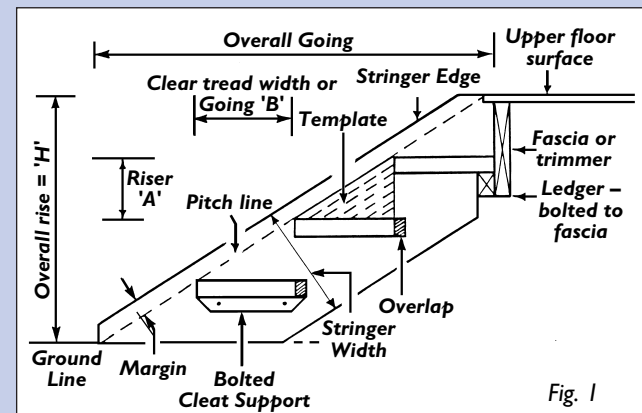

Unfortunately, there is no such thing as a set of steps to fit every location. Each set of steps should be designed to suit the particular situation.

See your local council authority to ensure that your design is made to required regulations.

NOTE THAT:

- A All risers should be of equal height.
- B Step treads should be a minimum clear width of 245 mm.
- C Ideal riser level is between 150 and 180 mm.
- D Use same size material for stringers and treads ie. 290 x 45 mm.

## DESIGN AND CALCULATE

1. Measure overall riser or the height of the steps. (i.e. from pathway to upper surface of deck). For example – this height 'H' is 640 mm.
  2. Calculate the number of steps required and the resulting riser height 'A' (needs to be between 140 and 180 mm).  
Example: Divide step height 'H' by 165 mm. Result – not a whole number ( $3^{145/65}$ ) but this indicates three or four risers may be needed.
    - Divide H by 3 = 213 mm – too large.
    - Divide H by 4 = 160 mm – which is satisfactory.
    - Divide H by 5 = 128 mm – too small.
- Result: 4 steps or risers 'A' of 160 mm.

## 3. TREAD WIDTH

Calculate clear tread width or going. (Minimum 245 mm). Use standard available timber sizes.  
Example: Using 290 x 45 mm finished size timber we will have a clear tread width of 265 mm, leaving a 25 mm overlap.

## 4. TEMPLATE

Using a carpenter's square, mark the riser height – 'A' and the clear tread width – 'B' on a piece of hardboard or very thick cardboard and measure the pitchline – 'C' (Fig. 2), carefully cut the template for later use.

Example: 'A' = 160 mm  
'B' = 265 mm  
'C' = 309.6 mm (measured)

Total timber width = 290 mm leaving a 25 mm overlap.

5. Now **calculate the stringer length**. Multiply the pitchline 'C' x the number of risers – 'A' and add 50 mm to allow for margin.

Example:  $4 \times 'C' (309.6 \text{ mm}) + 50 \text{ mm} = 1288 \text{ mm}$ .

## 6. PURCHASE TIMBER AND FIXINGS

Taking note of the above calculations and 'Materials Check List' on rear of this brochure, place your order for all the required items from your nearest Bowens store including stringers, treads, cleats, ledger beam, brackets, bolts etc. Remember that it is advisable to use same size timbers for stringers and treads.

## 7. MARK OUT STRINGERS

Cut two stringers to equal length.  
Example: 2 pieces 1350 mm long – 290 x 45 mm.  
Mark a margin line 50 mm from upper edge of stringer. This will now become the Pitch Line.

Starting at the bottom hold the template against the pitch line and accurately mark tread widths and risers on stringer (Fig. 3). Next mark thickness of treads (same thickness as stringer) then mark the other stringer in mirror image (Fig. 4)

Outline and mark position of the cut out for ledger as well as the necessary cut away to fit the angle bracket at foot of steps (Fig. 5).

## 8. CUT AND FIX CLEATS

Cut cleats (Fig. 7) to pattern shown, drill 8 mm holes and fasten securely to stringer in correct position using galvanised bolts, nuts and washers, seal all cut ends with 'Reseal' or similar sealer treatment.

## 9. FIT LEDGER

Cut ledger to size to project some 150 mm each side of stringers.  
Example: For 900 mm tread width this would require a ledger 1300 mm long (allowing for thickness of stringer).

Then fix ledger in place to fascia or trimmer board or edge of deck using four galvanised bolts or coach screws (Fig. 8) and mark ledger for final stringer position.  
For alternate method of fixing stringers to upper joists see Figure 9.

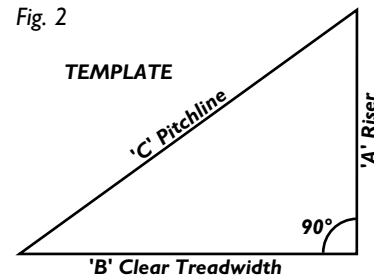

## DIAGRAMS SHOWING MARKINGS AND SET OUT FOR STRINGERS, CLEATS AND LEDGER

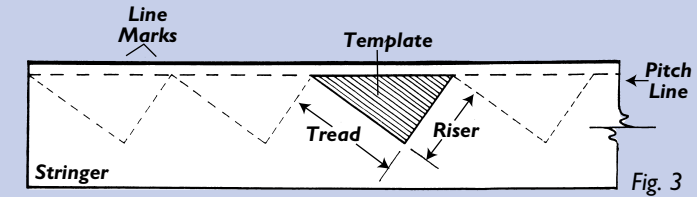

Do same as above in mirror image to the other stringer

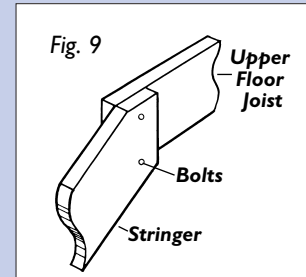
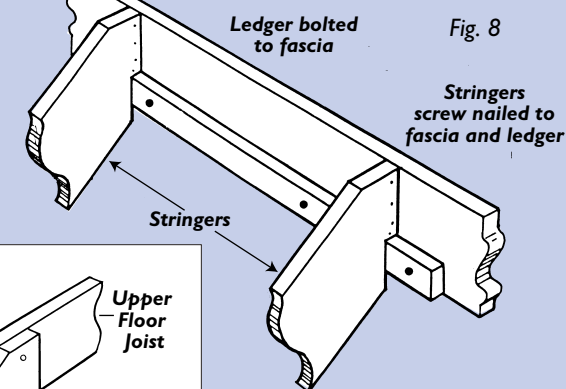
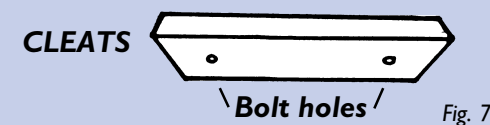
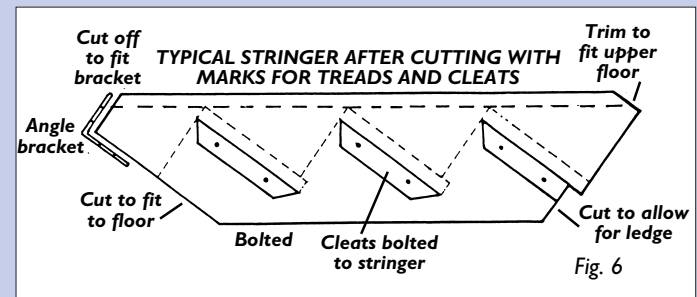
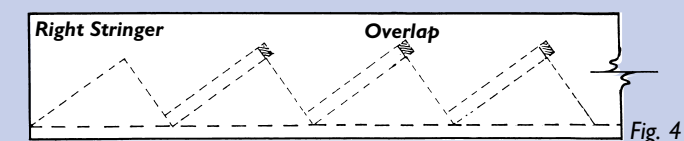
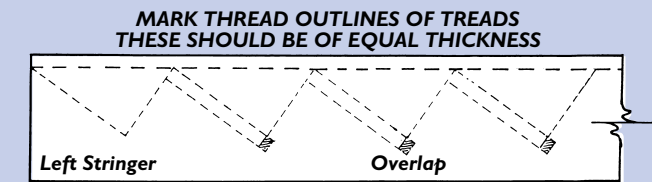

Alternative method of fixing stringer to upper floor joists. NOTE: Spacing of stringers must suit spacing of joists.

## 10. FIX STRINGERS TO LEDGER AND BRACKETS

Locate and mark position of angle brackets, drill appropriate holes in concrete and securely fix brackets into position using countersunk masonry anchors (Fig. 10).

NOTE: Make sure you allow for correct tread width.

Example: For 900 mm tread width the distance between centre of brackets should be 945 mm.

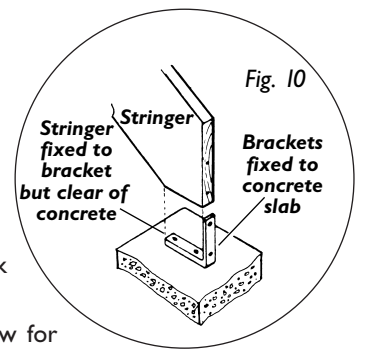

Before fixing stringers make sure that all cut ends are treated with 'reseal' or similar appropriate sealer treatment. Enquire at your nearest Bowens store for supply of sealer.

Place tread on cleats and ensure that steps are level. Now skew nail stringers securely to ledger (Fig. 8) and fasten stringers to brackets using galvanised screws (Fig. 10).

## 11. TREADS

Cut treads to length required.  
Example: Three treads of 900 mm long.  
Treat ends liberally with sealer treatment, fix treads into place, nailing through predrilled holes into cleats and through stringer into the end of treads (Fig. 11).

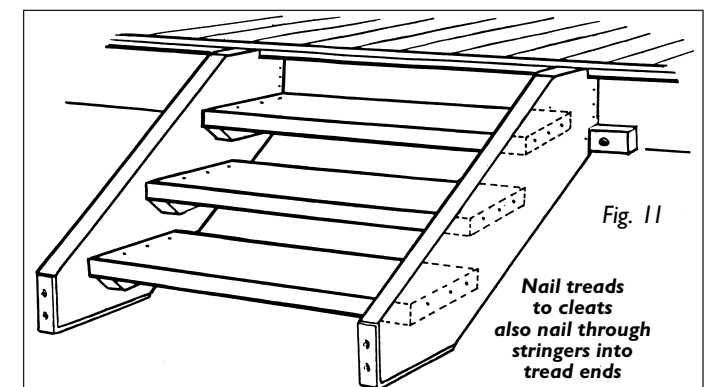

## 12. HANDRAILS

All decks higher than 600 mm must have a handrail, 1 metre high with maximum gaps of 150 mm between balusters or rails (Fig. 12.). Posts are ideally an extension of the stumps. See Bowens 'Timber Deck' brochure for handrails and post setting details.

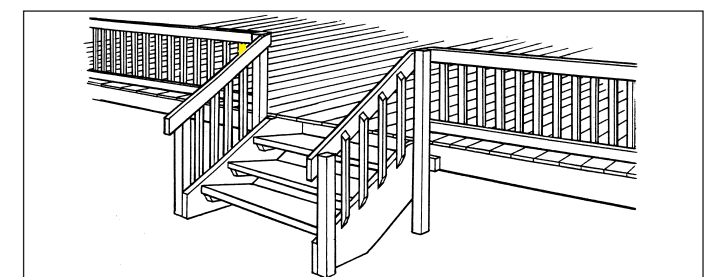

## FINISHING

Sand off sharp corners and trim top of stringers level with deck (Fig. 1). Apply suitable exterior type finish to your new set of steps.